



Mass Flow Controller AFC 261 & Meter AFM 361

Features

The traditional analog Qualiflow AFC 261 and AFM 361 with elastomeric seals and reliable thermal valve :

- Compatible with other MFC
- Economic design, simple construction.
- Outstanding records throughout various industries.
- Possibility to regulate with external readout.



Case GND	1	A	Setpoint
Common	2	B	Common
Readout	3	C	Common
+15 VDC	4	D	Valve control
	5	E	
Test point	6	F	-15 VDC
	8	J	Sensor Up-stream
	9	K	Sensor Com
Extra I/O	10	L	Sensor Down-stream

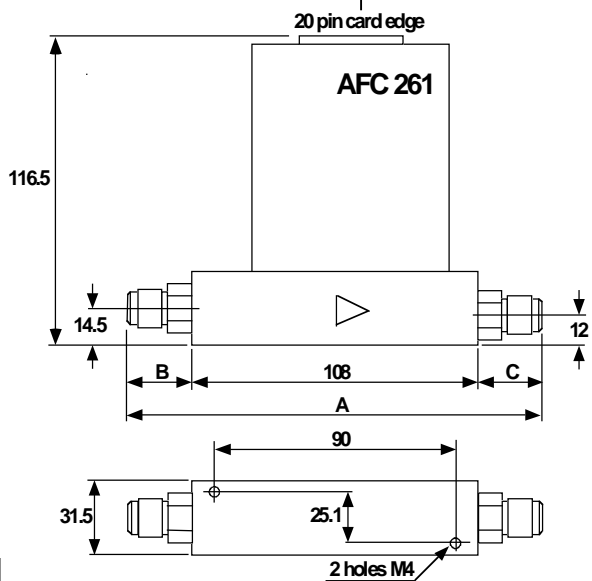

Table of Dimension (mm)

	VCR 1/4" MM	SWAGelok 1/4"
A (mm)	156.5	162.5 (inc. nuts)
B (mm)	24.7	29.0
C (mm)	23.8	25.5

Ratings

Flow Range (equivalent N2) :.....from 10 slm to 20 slm
 Control Range :..... between 2 and 100% F.S.
 Valve Type :..... Thermal
 Valve Rest Position :..... Normally Open only
 Accuracy :..... +/- 1% of F.S.
 Linearity :..... +/- 0.5% of F.S.
 Repeatability :..... +/- 0.3% of F.S.
 Step Response Time :..... <= 6 sec. typical (SEMI E17-91)
 Temperature Range :..... between 5 and 40°C
 Temperature Coefficient :..... < 0.1% F.S. /°C
 Maximum Inlet Pressure :..... 10 bar
 Minimum Differential Pressure :..... 0.5 bar (0.7 bar with H2)
 Maximum Differential Pressure :..... 3 bar
 Pressure Coefficient :..... < 0.1% F.S./bar
 Wetted Materials :..... 316 L Stainless steel
 Leak Integrity :..... < 2.10⁻⁸ scc/sec (He)
 Standard Seals :..... Viton, Neoprene
 Fittings :..... 1/4" VCR, Swagelok

Power Input Requirement :

Mass Flow Controller :..... +/- 15 VDC, 150 mA
 Mass Flow Meter :..... +/- 15 VDC, 25 mA
 Set Point Signal :..... from 0 to 5 VDC
 Flow Output Signal :..... from 0 to 5 VDC
 Electrical Connector :..... Card Edge

Options :

- Kalrez seals
- Separated electronics
- External readout
- Other on request

Gas Process Number

Symbol	Gas Name	Number	Density SEMI E52-0298	Sp. Heat [g / l]	C [cal/g/°C]
	Air	8	1.2929	0.2401	1.000
NH3	Ammonia	29	0.7710	0.519	0.68
Ar	Argon	4	1.7842	0.1246	1.453
AsH3	Arsine	35	3.481	0.1178	0.666
BCl3	Boron Trichloride	70	5.26	0.130	0.40
CO	Carbon Monoxide	9	1.2500	0.495	1.000
CCl4	Carbon Tetrafluoride	101	6.86	0.141	0.309
Cl2	Chlorine	19	3.209	0.116	0.83
B2H6	Dibirane	58	1.24	0.495	0.44
SiH2Cl2	Dichlorosilane	67	4.54	0.141	0.43
CHF3	Fluoroform	49	3.125	0.173	0.506
CCl2F2	Freon-12	84	5.5	0.149	0.34
CF4	Freon-14	63	3.96	0.167	0.41
GeH4	Germane	43	3.423	0.138	0.58
He	Helium	1	0.1788	1.242	1.454
H2	Hydrogen	7	0.0899	3.400	1.016
HCl	Hydrogen Chloride	11	1.635	0.1937	0.981
C2F6	Hexafluoroethane	118	6.16	0.185	0.24
Kr	Krypton	5	3.73	0.0596	1.45
CH4	Methane	28	0.7166	0.528	0.722
CH3SiCl3	Methyltrichlorosilane	183	6.670	0.164	0.250
N2	Nitrogen	13	1.2503	0.2484	1.000
NO2	Nitrogen Dioxide	26	6.675	0.194	0.41
NF3	Nitrogen Trifluoride	53	3.173	0.178	0.434
N2O	Nitrous Oxide	27	1.98	0.206	0.206
O2	Oxygen	15	1.429	0.2183	0.996
O3	Ozone	30			
PH3	Phosphine	31	1.523	0.2607	0.688
C3H8	Propane	89	1.98	0.392	0.35
SiH4	Silane	39	1.438	0.3188	0.596
SiF4	Silicon Tetrafluoride	88	4.68	0.168	0.35
Si2H6	Disilane	97			
SO2	Sulphur Dioxide	32	2.91	0.149	0.67
SF6	Sulphur Hexafluoride	110	6.5	0.1590	0.27
TiCl4	Titanium Tetrachloride	114	8.465	0.22	0.30
C4F8	Octafluorocyclohexane	129			
SiHCl3	Trichlorosilane	147	6.047	0.130	0.348