



# Mass Flow Meter AFM 11



## Features

A small flow meter designed to replace rotameter whenever an electrical signal of the flow measurement is required :

- Low cost design, simple construction
- Small footprint
- CE marking, UL on request
- Accuracy up to +/- 2% F.S.

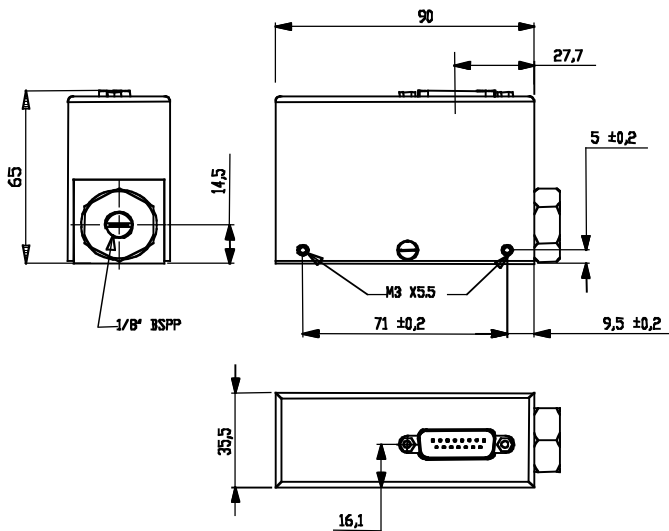

D 15 pin

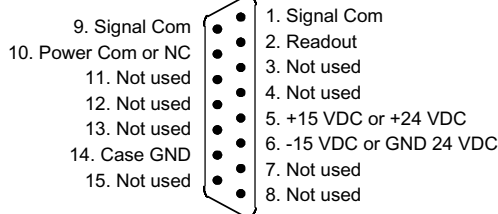

## Ratings

Flow Range (equivalent N2) : ..... from 60 slm to 120 slm  
 Accuracy : ..... +/- 5% of F.S.  
 ..... +/- 2% of F.S. (option)  
 Linearity : ..... +/- 0.5% of F.S.  
 Repeatability : ..... +/- 0.3% of F.S.

Temperature Range : ..... between 5 and 40°C  
 Temperature Coefficient : ..... < 0.1% F.S./°C

Maximum Inlet Pressure : ..... 10 bar  
 Pressure Coefficient : ..... < 0.1% F.S./bar

Wetted Materials : ..... Brass, Aluminium, 316L as option

Leak Integrity : ..... <10<sup>-6</sup> scc/sec (He)  
 Standard Seals : ..... Viton

Fittings : ..... 1/8" BSPP

## Power Input Requirement :

Dual : ..... + 15 VDC +/- 5% , 25 mA  
 ..... - 15 VDC +/- 5% , 30 mA

Flow Output Signal : ..... from 0 to 5 VDC  
 Electrical Connector : ..... Sub-D 15 pin male

## Options :

- Power supply + 24 VDC
- Output signal 4 to 20 mA
- 316L Stainless Steel body
- Power input of + 24 VDC, 64 mA
- Flow output signal of 4 to 20 mA