

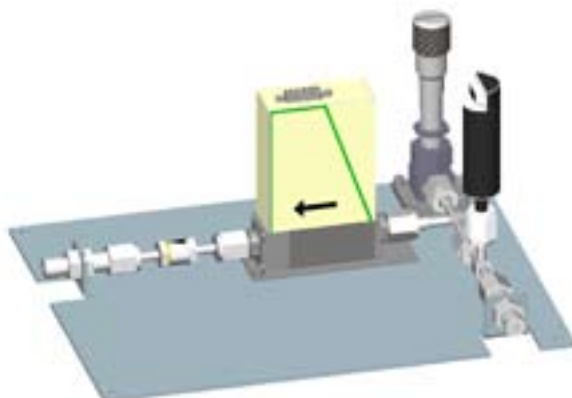

JetPress

Integrated Solution

Low Flow Pressure Controller with extremely stable pressure over time achieved



Qualiflow's pressure regulation system has been developed to increase the stability of vapor flow in a direct liquid injection system. Our experience has shown that small variations in the push gas pressure can lead to larger variations in vapor delivery. In many cases a simple pressure regulator does not provide enough pressure control.

The pressure control system can be seen as a second stage pressure regulator. A standard gas MFC with an external sensor input option is located in a by-pass line that controls the pressure upstream from the liquid container. The pressure transducer output signal enters the PID routine of the MFC and is compared with a pressure setpoint value. The MFC's valve opens if the pressure reading is greater than the setpoint value and closes if it is smaller. The total flow into the liquid canister and through the bypass line is set by the needle valve. The flow through the by-pass line is measured by the MFC's sensor.

The performance of this system is improved if a first stage pressure regulator is installed upstream. In addition, we recommend that the output of the gas MFC is connected to a vacuum pump in order to minimize the risk of air entering the pressurization line. Any air leakage could cause contamination and/or decomposition of the liquid precursor.

The gas flow through the bypass line must be roughly 10 times greater than the flow through the pressurization line. The gas flow through the pressurization line is equal to the volumetric liquid flow. This information allows the user to adjust the flow through the bypass line.

Technical Specifications

Hardware components

The pressure control system includes :

- Manual needle valve
- Pressure sensor
- Qualiflow Digital MFC, with an external sensor input option and calibrated for the process gas, specified by the customer in the purchase order
- Check valve to minimize the risk of air backflowing into the pressurization line
- Panel on which all the above mentioned parts are fixed
- All necessary cables for the MFC and pressure transducer to connect to a computer or readout box and power supply. The cable connecting to the power supply, along with the analog input and output signals, has a free end with no connector. One RS232 cable is provided to allow a dedicated PC or PLC to control the system digitally. Qualiflow's Digisoft software is also included.

Dimensions

L x W x H (mm).....329 x 260 x 161

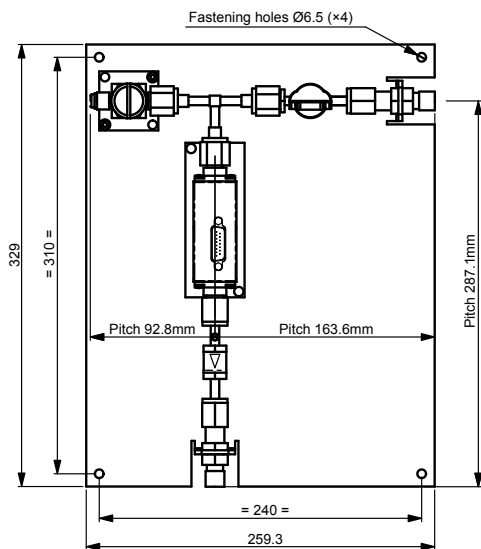

Specifications

Pressure control range*.....0-689 kPa (0-6.89 bara; 0-100 psia)

* Note : This assumes that the bypass line outlet is connected to vacuum.

Pressure measurement accuracy..... $\pm 1\%$ of reading

Pressure control accuracy..... ± 50 Pa (± 0.5 mbar; ± 375 mTorr)

Pressure variations..... $< \pm 4$ Pa/sec (± 0.04 mbar/s; ± 30 mTorr/s)

Gas flow.....500 sccm

Flow measurement and control accuracy..... $< \pm 1\%$ F.S.

Settling time.....10-60 sec, depending upon bypass flow

Materials :

Gas wetted path.....Incoloy, 316 and 316L ss, Viton, Kel-F

Limitations :

Maximum liquid flow......5 g/min

Upstream pressure.....800-1,000 kPa (8-10 bara; 116-145 psia)

Inputs & Outputs

Input power (power supply not provided) :

.....+ 15V DC / < 210 mA

.....- 15V DC / < 200 mA

Input signal (signal controller not provided) :

Pressure setpoint.....0-5V analog and digital (RS232)

Output signals (signal controller not provided) :

Pressure.....0-5V analog and digital (RS232)

Gas flow.....0-5V analog and digital (RS232)

Fittings

Inlet (x1)..... $\frac{1}{4}$ " Male VCR

Outlet (x2)..... $\frac{1}{4}$ " Male VCR

